

TO-220 Power Resistors- TR20



Features:

- 20 Watt at 25°C Case Temperature Heat Sink Mounted
- TO-220 Style Power Package
- Molded Case for Protection and Easy to Mount.
- Isolated Case.
- Non Inductive.

Applications:

- High Speed Switching Power Supplies.
- Snubber Circuits.
- Load Resistor for Pulse Generators.
- Voltage Regulation.
- VHF Amplifiers.

Dimensions

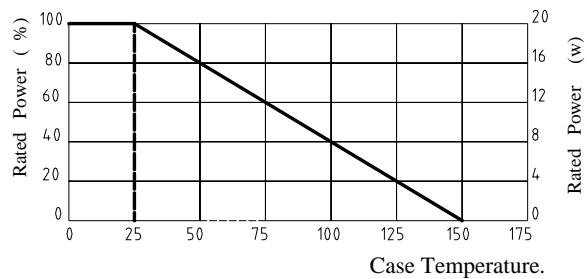
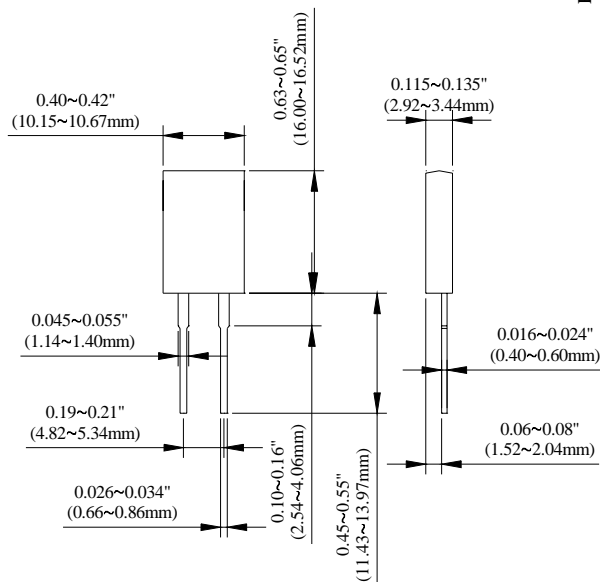

Part Numbering

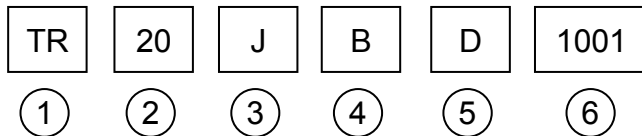

①Product Type

Product Type	Type
TR	TO-220 Power Resistors

②Power

Codes	Power Rating
20	20 Watts

③Resistance Tolerance

Codes	Resistance Tolerance
D	±0.5%
F	±1%
G	±2%
J	±5%
K	±10%

④Packaging

Code	Type
T	Tube
B	Bulk

⑤TCR

Codes	Type
D	±50PPM/°C
E	±100PPM/°C
F	±200PPM/°C
-	No specified

⑥ Resistance

Codes	Type
0R10	0.1Ω
0100	10Ω
4700	470Ω
1001	1000Ω
1002	10000Ω

Electrical Characteristics Specifications

Resistance Range	Resistance Tolerance	TCR (PPM/°C)
0.05Ω~1Ω	±5.00% ±10.0%	--
2Ω~5Ω	±1.00% ±5.00% ±10.0%	±200
5Ω~10Ω	±1.00% ±5.00% ±10.0%	±100 ±200
11Ω~10KΩ	±0.50% ±1.00% ±5.00% ±10.0%	±50 ±100 ±200

- Operating Voltage:350V Max.
- Dielectric Strength: 1800VAC
- Insulation Resistance: 10GΩmin.
- Working Temperature Range:-65°C to +150°C
- Resistance Value< 1Ω is Available

Environmental Characteristics

Test Item	Specification	Test Method
Temperature Coefficient of Resistance	10Ω and above, ±50ppm/°C 1Ω and 10Ω,(± 100ppm)/°C	Referenced to 25°C, ΔR taken at +105°C
Short Time Overload	ΔR± 0.3%	2 times rated power with applied voltage not to exceed 1.5 times maximum continuous operating voltage for 5 seconds.
Load Life	ΔR ± 1.0%	MIL-R-39009, 2,000 hours at rated power.
Humidity (Steady State)	ΔR± 0.5%	MIL-STD-202F, Method 103B 40°C,90~95%RH,RCWV 1.5hours ON,0.5hours OFF. total 1000~1048 hours.
Thermal Shock	ΔR ± 0.3%	MIL-STD-202, Method 107G. -65°C~150°C, 100 cycle
Terminal Strength	ΔR ± 0.2%	MIL-STD-202, Method 211, Cond. A (Pull Test) 2.4N.
Vibration, High Frequency	ΔR ± 0.2%	MIL-STD-202, Method 204, Cond. D.

- Lead Material: Tinned Copper.
- Without a Heat Sink.
- When in Free Air at 25°C, the TR20 is Rated for 3W.
- The Case Temperature is to be used for the Definition of the Applied Power Limit.
- The Case Temperature Measurement Must be Made with a Thermocouple Contacting the Center of the Component Mounted on the Designed Heat Sink.
- Thermal Grease Should be Applied Properly.

TO-220 Power Resistors- TR30



Features:

- 30 Watt at 25°C Case Temperature Heat Sink Mounted
- TO-220 Style Power Package
- Single Screw Mounting to Heat Sink.
- Molded Case for Protection and Easy to Mount.
- Isolated Case.
- Non Inductive.

Applications:

- Gate Resistors in Power Supplies.
- Snubbers.
- Load and Dumping Resistors in CRT Monitors.
- Terminal Resistance in RF Power Amplifiers.
- Voltage Regulation.
- Low Energy Pulse Loading.
- UPS

Dimensions:

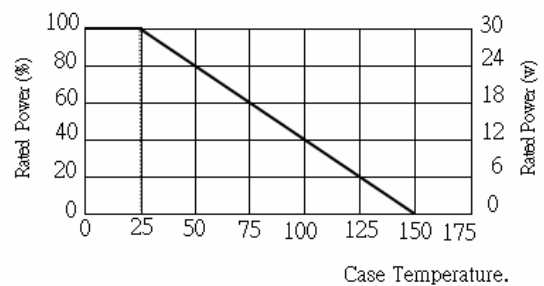
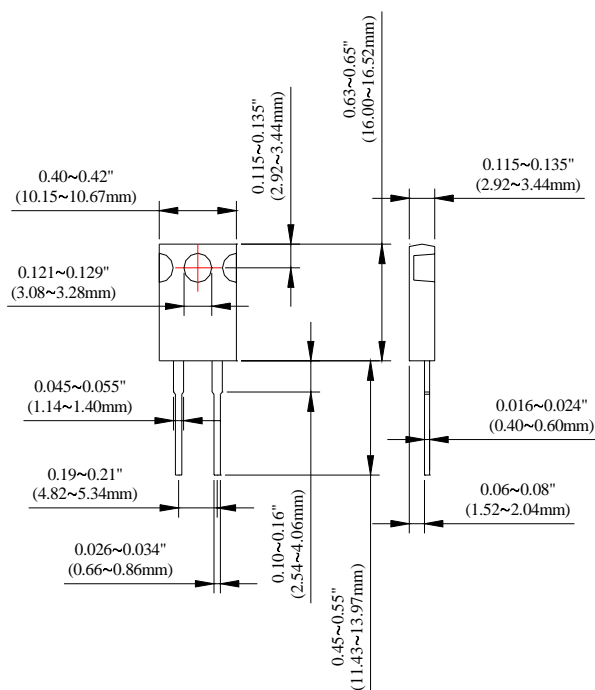

Part Numbering

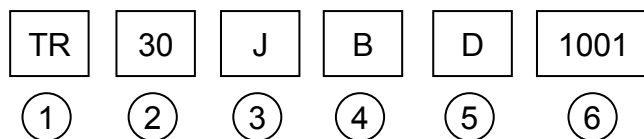

① Product Type

Product Type	Type
TR	TO-220 Power Resistors

② Power

Codes	Power Rating
30	30 Watts

③ Resistance Tolerance

Codes	Resistance Tolerance
D	±0.5%
F	±1%
G	±2%
J	±5%
K	±10%

④ Packaging

Code	Type
T	Tube
B	Bulk

⑤ TCR

Codes	Type
D	±50PPM/°C
E	±100PPM/°C
F	±200PPM/°C
-	No specified

⑥ Resistance

Codes	Type
0R10	0.1Ω
0100	10Ω
4700	470Ω
1001	1000Ω
1002	10000Ω

Electrical Characteristics Specifications

Resistance Range	Resistance Tolerance	TCR (PPM/°C)
0.05Ω~1Ω	±5.00% ±10.0%	--
2Ω~5Ω	±1.00% ±5.00% ±10.0%	±200
5Ω~10Ω	±1.00% ±5.00% ±10.0%	±100 ±200
11Ω~10KΩ	±0.50% ±1.00% ±5.00% ±10.0%	±50 ±100 ±200

- Operating Voltage:350V Max.
- Dielectric Strength: 1500VAC
- Insulation Resistance: 10GΩmin.
- Working Temperature Range:-65°C to +150°C
- Resistance Value <10Ωis Available

Environmental Characteristics

Test Item	Specification	Test Method
Temperature Coefficient of Resistance	10Ω and above, ±50ppm/°C 1Ω and 10Ω,(± 100ppm)/°C	Referenced to 25°C, ΔR taken at +105°C
Short Time Overload	ΔR± 0.3%	2 times rated power with applied voltage not to exceed 1.5 times maximum continuous operating voltage for 5 seconds.
Load Life	ΔR ± 1.0%	MIL-R-39009, 2,000 hours at rated power.
Humidity (Steady State)	ΔR± 0.5%	MIL-STD-202F, Method 103B 40°C,90~95%RH,RCWV 105hours ON,0.5hours OFF, total 1000~1048 hours.
Thermal Shock	ΔR ± 0.3%	MIL-STD-202, Method 107G. -65°C~150°C, 100 cycle
Terminal Strength	ΔR ± 0.2%	MIL-STD-202, Method 211, Cond. A (Pull Test) 2.4N,
Vibration, High Frequency	ΔR ± 0.2%	MIL-STD-202, Method 204, Cond. D,

- Lead Material: Tinned Copper.
- Maximum Torque: 0.9 Nm.
- When in Free Air at 25°C, the TR30 is Rated for 2.25W.
- The Case Temperature is to be used for the Definition of the Applied Power Limit.
- The Case Temperature Measurement Must be Made with a Thermocouple Contacting the Center of the Component Mounted on the Designed Heat Sink.
- Thermal Grease Should be Applied Properly.

TO-220 Power Resistors- TR35

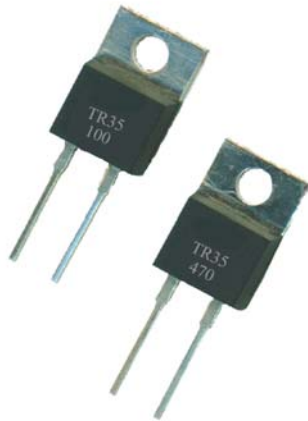

Features:

- 35 Watt @ 25°C Case Temperature Heat Sink Mounted.
- TO-220 Style Power Package.
- Single Screw Mounting to Heat Sink.
- Low Thermal Resistance to Heat Sink @ $R_{th} < 4.28 \text{ } ^\circ\text{C/W}$.
- Molded Case for Protection and Easy to Mount.
- Isolated Case.
- Non Inductive.

Applications:

- Switching Power Supplies.
- Snubbers Circuits.
- Automated Machine Controller.
- RF Power Amplifiers.
- Low Energy Pulse Loading.
- UPS.
- Voltage Regulation.

Dimensions:

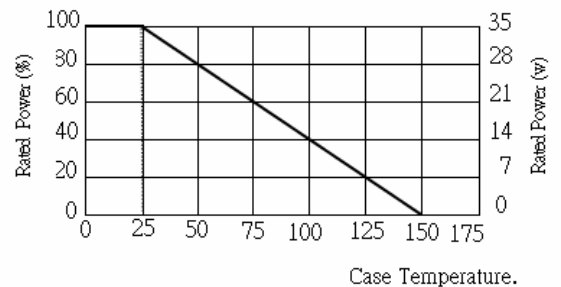
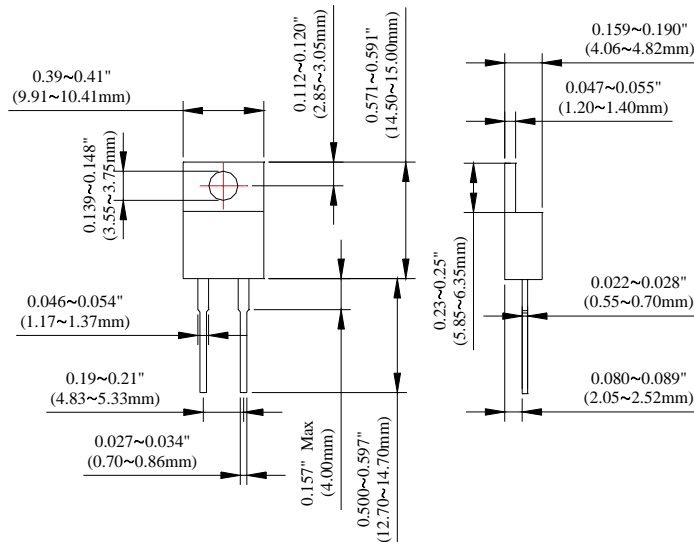

Part Numbering

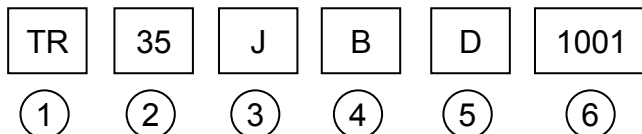

① Product Type

Product Type	
TR	TO-220 Power Resistors

② Power

Codes	Power Rating
35	35 Watts

③ Resistance Tolerance

Codes	Resistance Tolerance
D	±0.5%
F	±1%
G	±2%
J	±5%
K	±10%

④ Packaging

Code	Type
T	Tube
B	Bulk

⑤ TCR

Codes	Type
D	±50PPM/°C
E	±100PPM/°C
F	±200PPM/°C
-	No specified

⑥ Resistance

Codes	Type
0R10	0.1 Ω
0100	10 Ω
4700	470 Ω
1001	1000 Ω
1002	10000 Ω

Electrical Characteristics Specifications

Resistance Range	Resistance Tolerance	TCR (PPM/°C)
0.05Ω~1Ω	±5.00% ±10.0%	--
2Ω~5Ω	±1.00% ±5.00% ±10.0%	±200
5Ω~10Ω	±1.00% ±5.00% ±10.0%	±100 ±200
11Ω~10KΩ	±0.50% ±1.00% ±5.00% ±10.0%	±50 ±100 ±200

- Operating Voltage:350V Max.
- Dielectric Strength: 1800VAC
- Insulation Resistance: 10GΩmin.
- Working Temperature Range:-65°C to +150°C
- Resistance Value < 1Ω is Available

Environmental Characteristics

Test Item	Specification	Test Method
Temperature Coefficient of Resistance	10Ω and above, ±50ppm/°C 1Ω and 10Ω,(± 100ppm)/°C	Referenced to 25°C, ΔR taken at +105°C
Short Time Overload	ΔR±0.3%	2 times rated power with applied voltage not to exceed 1.5 times maximum continuous operating voltage for 5 seconds,
Load Life	ΔR ± 1.0%	MIL-R-39009, 2,000 hours at rated power.
Humidity (Steady State)	ΔR± 0.5%	MIL-STD-202F, Method 103B 40°C,90~95%RH,RCWV 105hours ON,0.5hours OFF, total 1000~1048 hours.
Thermal Shock	ΔR± 0.3%	MIL-STD-202, Method 107G. -65°C~150°C, 100 cycle.
Terminal Strength	ΔR ± 0.2%	MIL-STD-202, Method 211, Cond. A (Pull Test) 2.4N,
Vibration, High Frequency	ΔR± 0.2%	MIL-STD-202, Method 204, Cond. D,

- Lead Material: Tinned Copper
- Maximum Torque: 0.9 N-m
- Without a Heat Sink, When in Free Air at 25°C, the TR35 is Rated for 2.50W.
- The Case Temperature is to be used for the Definition of the Applied Power Limit.
- The Case Temperature Measurement Must be Made with a Thermocouple Contacting the Center of the Component Mounted on the Designed Heat Sink.
- Thermal Grease Should be Applied Properly.

TO-220 Power Resistors- TR50



Features:

- 50 Watt @ 25°C Case Temperature Heat Sink Mounted.
- TO-220 Style Power Package.
- Molded Case for Protection and Easy to Mount.
- Isolated Case.
- Low ohm value.

Applications:

- Switching Power Supplies.
- Non-inductive design for high frequency.
- Pulsing applications.
- UPS.
- Voltage Regulation.

Dimensions:

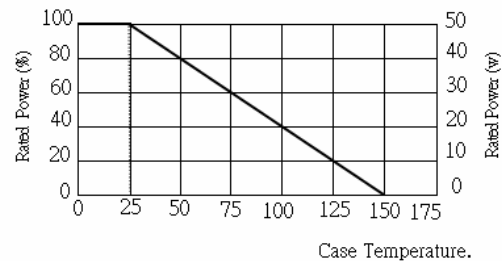
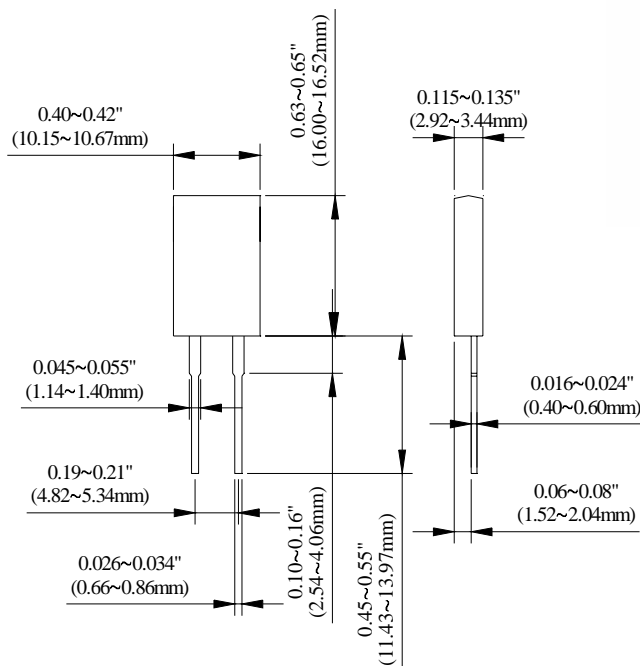

Part Numbering

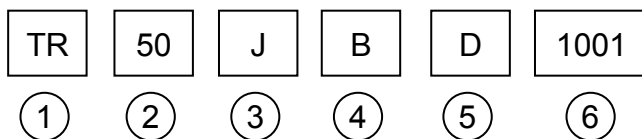

①Product Type

Product Type	
TR	TO-220 Power Resistors

②Power

Codes	Power Rating
50	50 Watts

③Resistance Tolerance

Codes	Resistance Tolerance
D	±0.5%
F	±1%
G	±2%
J	±5%
K	±10%

④Packaging

Code	Type
T	Tube
B	Bulk

⑤TCR

Codes	Type
D	±50PPM/°C
E	±100PPM/°C
F	±200PPM/°C
-	No specified

⑥ Resistance

Codes	Type
0R10	0.1Ω
0100	10Ω
4700	470Ω
1001	1000Ω
1002	10000Ω

Electrical Characteristics Specifications

Resistance Range	Resistance Tolerance	TCR (PPM/°C)
0.05Ω~1Ω	±5.00% ±10.0%	--
2Ω~5Ω	±1.00% ±5.00% ±10.0%	±200
5Ω~10Ω	±1.00% ±5.00% ±10.0%	±100 ±200
11Ω~10KΩ	±0.50% ±1.00% ±5.00% ±10.0%	±50 ±100 ±200

- Operating Voltage:350V Max.
- Dielectric Strength: 1800VAC
- Insulation Resistance: 10GΩmin.
- Working Temperature Range:-65°C to +150°C
- Resistance Value < 1Ω is Available

Environmental Characteristics

Test Item	Specification	Test Method
Temperature Coefficient of Resistance	10Ω and above, ±50ppm/°C 1Ω and 10Ω,(± 100ppm)/°C	Referenced to 25°C, ΔR taken at +105°C
Short Time Overload	ΔR± 0.3%	2 times rated power with applied voltage not to exceed 1.5 times maximum continuous operating voltage for 5 seconds.
Load Life	ΔR ± 1.0%	MIL-R-39009, 2,000 hours at rated power.
Humidity (Steady State)	ΔR± 0.5%	MIL-STD-202F, Method 103B 40°C, 90~95%RH, RCWV 105hours ON, 0.5hours OFF. total 1000~1048 hours
Thermal Shock	ΔR ± 0.3%	MIL-STD-202, Method 107G. -65°C~150°C, 100 cycle
Terminal Strength	ΔR ± 0.2%	MIL-STD-202, Method 211, Cond. A (Pull Test) 2.4N.
Vibration, High Frequency	ΔR ± 0.2%	MIL-STD-202, Method 204, Cond. D.

- Lead Material: Tinned Copper
- Maximum Torque: 0.9 N-m
- Without a Heat Sink, When in Free Air at 25°C, the TR50 is Rated for 3W.
- The Case Temperature is to be used for the Definition of the Applied Power Limit.
- The Case Temperature Measurement Must be Made with a Thermocouple Contacting the Center of the Component Mounted on the Designed Heat Sink.
- Thermal Grease Should be Applied Properly.