

# Thin Film Current Sensing Chip Resistor – TCS Series

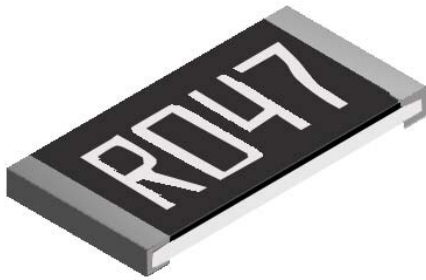

## Features

- Thin film process
- High power rating up to 3 Watts in 2512 size
- Tight tolerance down to  $\pm 0.5\%$
- Extremely low TCR down to  $\pm 50$  PPM/ $^{\circ}\text{C}$
- Resistance values from 50m to 1 ohm
- High purity alumina substrate for high power dissipation

## Applications

- Power Management Applications
- Switching Power Supply
- Over Current Protection in Audio Application
- Voltage Regulation Module (VRM)
- DC-DC Converter, Battery Pack, Charger, Adaptor
- Automotive Engine Control
- Disk Driver
- Portable Devices (PDA, Cell phone)

## Construction

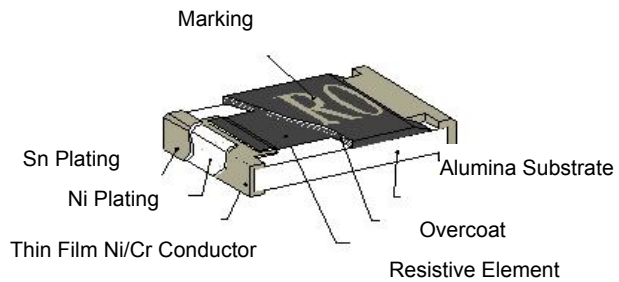

## Derating Curve

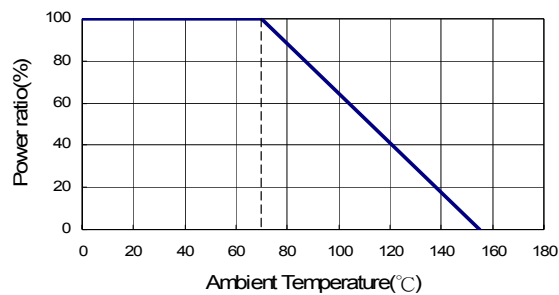

## Part Numbering

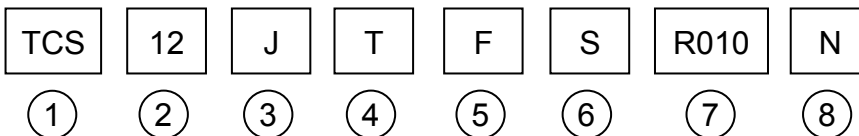

### ① Product Type

Product Type	Type
TCS	Thin Film Current Sensing Chip Resistor

### ② Dimensions (L×W)

Codes	Dimensions (LxW)	Type
TCS02	1.00×0.50mm	0402
TCS03	1.60×0.80mm	0603
TCS05	2.00×1.25mm	0805
TCS06	3.05×1.55mm	1206
TCS10	5.00×2.45mm	2010
TCS12	6.30×3.15mm	2512

### ③ Resistance Tolerance

Codes	Resistance Tolerance
J	$\pm 5\%$
F	$\pm 1\%$
D	$\pm 0.5\%$

### ④ Packaging

Codes	Type
T	Taping Reel
B	Bulk

### ⑤ TCR

Codes	Type
D	$\pm 50$ PPM/ $^{\circ}\text{C}$
E	$\pm 100$ PPM/ $^{\circ}\text{C}$
F	$\pm 200$ PPM/ $^{\circ}\text{C}$

### ⑥ Power Rating

Codes	Type
R	Standard
	3W

### ⑦ Resistance

Codes	Type
R010	0.010 $\Omega$
R100	0.100 $\Omega$
1R00	1.000 $\Omega$

### ⑧ Marking

Codes	Type
	Standard Marking*
N	No Marking

\*Please consult with us.

## Dimensions

Unit: mm

Codes	L	W	T	D1	D2
TCS02	1.00±0.05	0.50±0.05	0.32±0.10	0.25±0.10	0.20±0.10
TCS03	1.60±0.10	0.80±0.10	0.45±0.10	0.30±0.20	0.30±0.20
TCS05	2.00±0.15	1.25±0.15	0.55±0.10	0.30±0.20	0.40±0.25
TCS06	3.05±0.15	1.55±0.15	0.55±0.10	0.50±0.30	0.40±0.25
TCS10	5.00±0.20	2.45±0.15	0.60±0.15	0.60±0.30	0.50±0.25
TCS12	6.35±0.20	3.15±0.15	0.60±0.10	0.60±0.30	0.55±0.25

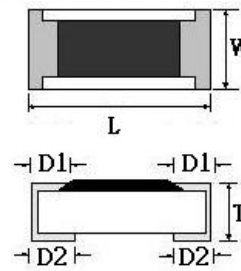

## Standard Electrical Specifications

Type	Item	Power Rating at 70°C	Operating Temp. Range	Resistance Tolerance	Resistance Range (mΩ)	TCR (PPM/°C)
TCS02 (0402)		1/16W	-55 ~ +155°C	±0.5%	500 ~ 1000	±100
				±1.0%		
TCS03 (0603)		1/10W		±0.5%	200 ~ 300	±100
					301 ~ 1000	±50
TCS05 (0805)		1/8W		±1.0%	200 ~ 300	±100
					301 ~ 1000	±50
TCS06 (1206)		1/4W		±1.0%	50 ~ 100	±200
					101 ~ 300	±100
				301 ~ 1000	±50	
TCS10 (2010)		3/4W	±0.5%	50 ~ 100	±200	
				101 ~ 300	±100	
				301 ~ 1000	±50	
TCS12 (2512)		1W	±0.5%	50 ~ 100	±200	
				101 ~ 300	±100	
				301 ~ 1000	±50	

Operating Current  $I = \sqrt{P/R}$ , Operating Voltage  $V = \sqrt{P \cdot R}$

## High Power Rating Electrical Specifications

Type	Item	Power Rating at 70°C	Operating Temp. Range	Resistance Tolerance	Resistance Range (mΩ)	TCR (PPM/°C)
TCS12 (2512)		3W	-55 ~ +155°C	±1.0%	100 ~ 1000	±100

\*Viking is capable of manufacturing the optional spec based on customer's requirement.

### Marking for 0603

Codes	Type
1R0	1.000Ω
R10	0.100Ω
R01	0.010Ω
<u>101</u>	0.101Ω
<u>035</u>	0.035Ω

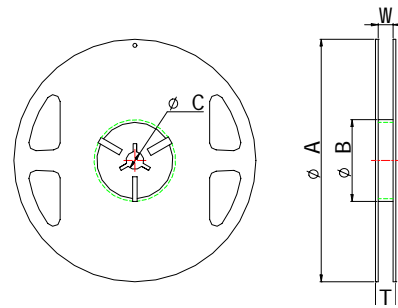

### Packaging

#### Packaging Quantity & Reel Specifications

Unit: mm

Packaging Codes	ΦA	ΦB	ΦC	W	T	Paper Tape (EA)	Emboss Plastic Tape (EA)
TCS02	178.0 ± 1.0	60.0 ± 1.0	13.5 ± 0.7	9.5 ± 1.0	11.5 ± 1.0	10,000	-
TCS03	178.0 ± 1.0	60.0 ± 1.0	13.5 ± 0.7	9.5 ± 1.0	11.5 ± 1.0	5,000	-
TCS05	178.0 ± 1.0	60.0 ± 1.0	13.5 ± 0.7	9.5 ± 1.0	11.5 ± 1.0	5,000	-
TCS06	178.0 ± 1.0	60.0 ± 1.0	13.5 ± 0.7	9.5 ± 1.0	11.5 ± 1.0	5,000	-
TCS10	178.0 ± 1.0	60.0 ± 1.0	13.5 ± 0.7	13.5 ± 1.0	15.5 ± 1.0	-	4,000
TCS12	178.0 ± 1.0	60.0 ± 1.0	13.5 ± 0.7	13.5 ± 1.0	15.5 ± 1.0	-	4,000

#### Paper Tape Specifications

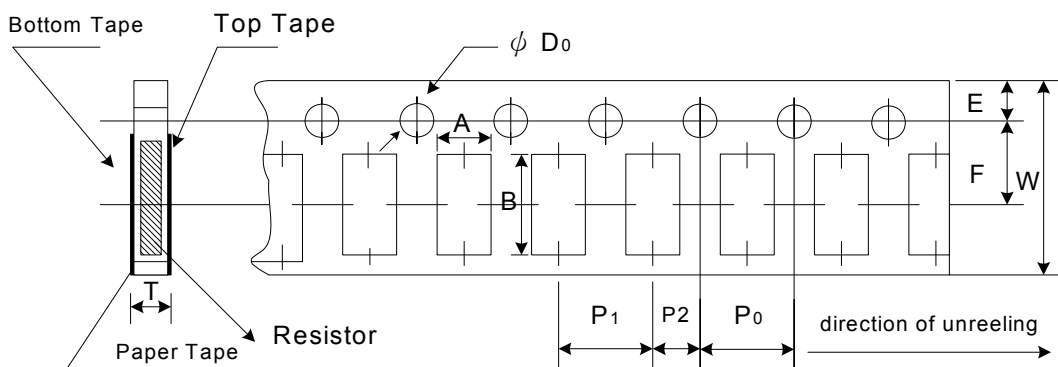

Unit: mm

Codes	A	B	W	E	F	P0	P1	P2	ΦD0	T
TCS02	0.70±0.05	1.16±0.05	8.00±0.10	1.75±0.05	3.5±0.05	4.00±0.10	2.00±0.10	2.00±0.05	1.55±0.05	0.40±0.03
TCS03	1.10±0.05	1.90±0.05	8.00±0.10	1.75±0.05	3.5±0.05	4.00±0.10	4.00±0.10	2.00±0.05	1.55±0.05	0.60±0.03
TCS05	1.60±0.05	2.37±0.05	8.00±0.10	1.75±0.05	3.5±0.05	4.00±0.10	4.00±0.10	2.00±0.05	1.55±0.05	0.75±0.05
TCS06	2.00±0.05	3.55±0.05	8.00±0.10	1.75±0.05	3.5±0.05	4.00±0.10	4.00±0.10	2.00±0.05	1.55±0.05	0.75±0.05

## Packaging

### Emboss Plastic Tape Specifications

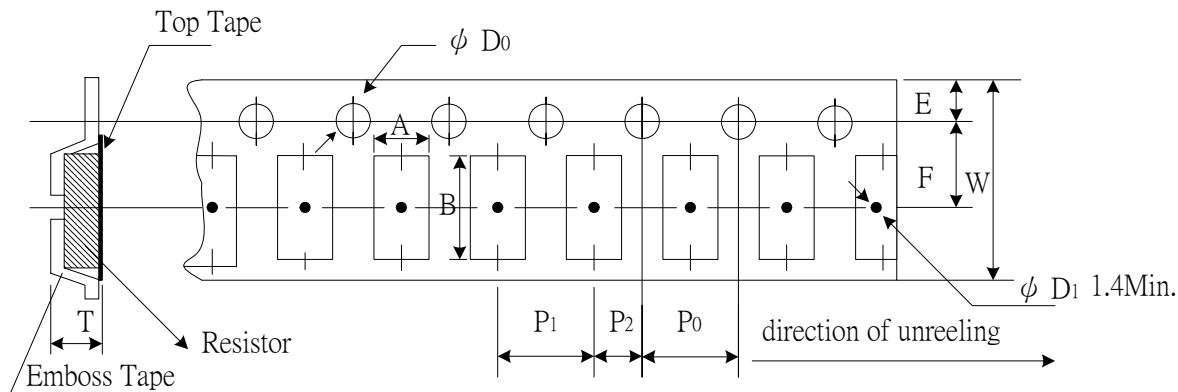

Unit: mm

Codes	A	B	W	E	F	P <sub>0</sub>	P <sub>1</sub>	P <sub>2</sub>	ΦD <sub>0</sub>	T
TCS10	2.85±0.10	5.45±0.10	12.0±0.10	1.75±0.10	5.5±0.05	4.00±0.05	4.00±0.10	2.00±0.05	1.50+0.10	1.00±0.20
TCS12	3.40±0.10	6.65±0.10	12.0±0.10	1.75±0.10	5.5±0.05	4.00±0.05	4.00±0.10	2.00±0.05	1.50+0.10	1.00±0.20

## Environmental Characteristics

Item	Specification	Test Method
1	Temperature Coefficient of Resistance As Spec	MIL-STD-202F Method 304 +25/-55/+25/+125/+25°C
2	Short Time Overload ±1%	JIS-C-5202-5.5 RCWV*2.5 or Max Overloading Voltage 5 seconds
3	Dielectric Withstand Voltage by Type	MIL-STD-202F Method 301 Apply Max Overload Voltage for 1 minute
4	Insulation Resistance >1000MΩ	MIL-STD-202F Method 302 Apply 100VDC for 1minute
5	Thermal Shock ±0.5%	MIL-STD-202F Method 107G -55°C ~ 150°C, 100cycles
6	Load Life ±1%	MIL-STD-202F Method 108A RCWV, 70°C, 1.5 hours on, 0.5 hours off Total 1000~1048 hours
7	Humidity (Steady State) ±0.5%	MIL-STD-202F Method 103B 40°C, 90~95%RH, RCWV 1.5 hours ON, 0.5 hours OFF, total 1000 ~ 1048 hours
8	Resistance to Dry Heat ±0.5%	JIS-C-5202-7.2 96hours @ +155°C without load
9	Low Temperature Operation ±0.5%	JIS-C-5202-7.1 1hour, -65°C followed by 45 minutes of RCWV
10	Bending Strength AS SPEC.	JIS-C-5202-6.1.4 Bending Amplitude 3mm for 10 seconds
11	Solderability 95%min coverage	MIL-STD-202F Method 208H 245°C±5°C, 3±0.5 (sec)
12	Resistance to Soldering Heat ±0.5%	MIL-STD-202F Method 210E 260±5°C, 10±1 seconds

\* Storage Temperature :25±3°C; Humidity <80%RH