

Anti-Corrosive Thin Film Precision Chip Resistor – PR Series

Features

Viking New Passivated NiCr Film appered stable performance at Moisture receptivity, Guarantee long term life stability and demonstrated the Anti –Corrosion claims Characterized by Tantalum

- Special Passivated NiCr Film for Anti-Acid and Anti-Damp
- Very Tight Tolerance from $\pm 0.1\%$
- Extremely Low TCR from ± 25 PPM/ $^{\circ}\text{C}$
- Wide R-Value Range



Construction

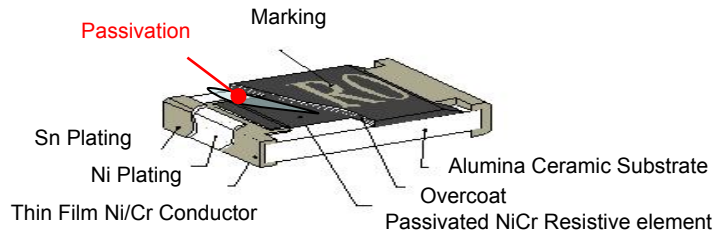

Applications

- Automotive
- High-end Computer
- Industrial Equipment
- Automatic Equipment Controller
- Medical Equipment
- Telecommunication Device
- High-end Multimedia Electronics

Derating Curve

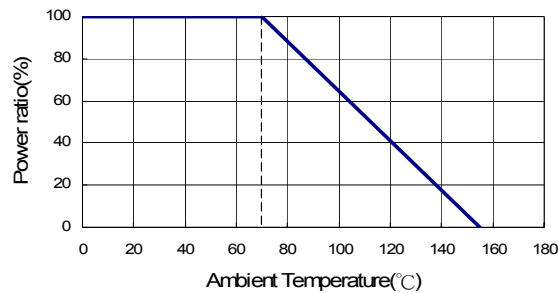

Part Numbering

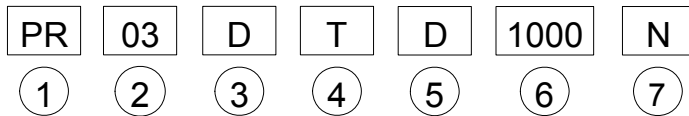

① Product Type

Product Type	
PR	Anti-Corrosive Thin film Precision Chip Resistor

② Dimensions (L×W)

Codes	Dimensions (L×W)	EIA
PR02	1.00×0.50mm	0402
PR03	1.60×0.80mm	0603
PR05	2.00×1.25mm	0805
PR06	3.00×1.50mm	1206
PR10	4.90×2.40mm	2010
PR12	6.30×3.10mm	2512

③ Resistance Tolerance

Codes	Resistance Tolerance
B	$\pm 0.10\%$
C	$\pm 0.25\%$
D	$\pm 0.50\%$

④ Packaging

Codes	Type
T	Taping Reel
B	Bulk

⑤ TCR

Codes	Type
C	± 25 PPM/ $^{\circ}\text{C}$
D	± 50 PPM/ $^{\circ}\text{C}$

⑥ Resistance

Codes	Type
1000	100 Ω
2201	2200 Ω
1002	10000 Ω
4992	49900 Ω
1003	100000 Ω

⑦ Marking

Codes	Type
	Standard Marking for E96 / E24
N	No Marking

Dimensions

Unit: mm

Codes	L	W	T	D1	D2
PR02	1.00±0.05	0.50±0.05	0.30±0.05	0.20±0.10	0.20±0.10
PR03	1.55±0.10	0.80±0.10	0.45±0.10	0.30±0.20	0.30±0.20
PR05	2.00±0.15	1.25±0.15	0.55±0.10	0.30±0.20	0.40±0.25
PR06	3.05±0.15	1.55±0.15	0.55±0.10	0.42±0.20	0.35±0.25
PR10	4.90±0.15	2.40±0.15	0.55±0.10	0.60±0.30	0.50±0.25
PR12	6.30±0.15	3.10±0.15	0.55±0.10	0.60±0.30	0.50±0.25

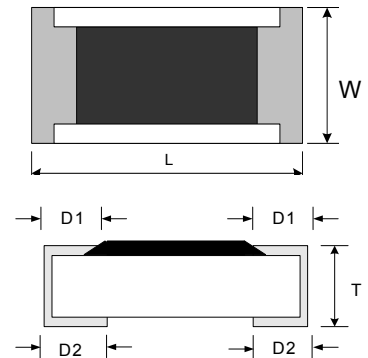

Standard Electrical Specifications

Item Type	Power Rating at 70°C	Operating Temp. Range	Max Operating Voltage	Max Overloading Voltage	Resistance Tolerance	Resistance Range	TCR (PPM/°C)
PR02 (0402)	1/16W	-55 ~ +155°C	25V	50V	±0.10% ±0.25% ±0.50%	25Ω~25KΩ	±25 ±50
PR03 (0603)	1/16W	-55 ~ +155°C	50V	100V	±0.10% ±0.25% ±0.50%	25Ω~332KΩ	±25 ±50
PR05 (0805)	1/10W	-55 ~ +155°C	100V	200V	±0.10% ±0.25% ±0.50%	10Ω~800KΩ	±25 ±50
PR06 (1206)	1/8W	-55 ~ +155°C	150V	300V	±0.10% ±0.25% ±0.50%	10Ω~1MΩ	±25 ±50
PR10(2010)	1/4W	-55 ~ +155°C	150V	300V	±0.10% ±0.25% ±0.50%	10Ω~1MΩ	±25 ±50
PR12 (2512)	1/2W	-55 ~ +155°C	150V	300V	±0.10% ±0.25% ±0.50%	10Ω~1MΩ	±25 ±50

Packaging

Packaging Quantity & Reel Specifications

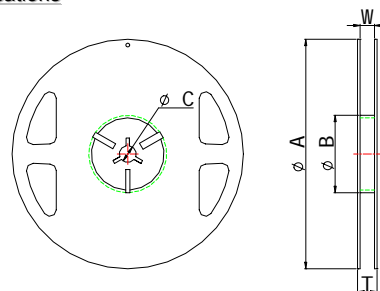

Unit: mm

Codes	ΦA	ΦB	ΦC	W	T	Paper Tape (EA)	Emboss Plastic Tape (EA)
PR02	178±1	60.0+0.5	13.0±0.20	9.00±0.50	12.0±0.15	10,000	-
PR03	178±1	60.0+0.5	13.0±0.20	9.00±0.50	12.0±0.15	5,000	-
PR05	178±1	60.0+0.5	13.0±0.20	9.00±0.50	12.0±0.15	5,000	-
PR06	178±1	60.0+0.5	13.0±0.20	9.00±0.50	12.0±0.15	5,000	-
PR10	178±1	60.2±0.5	13.0±1.00	13.2±1.50	16.0±0.20	-	4,000
PR12	178±1	60.2±0.5	13.0±0.50	13.2±1.50	16.0±0.20	-	4,000

Packaging

Paper Tape Specifications

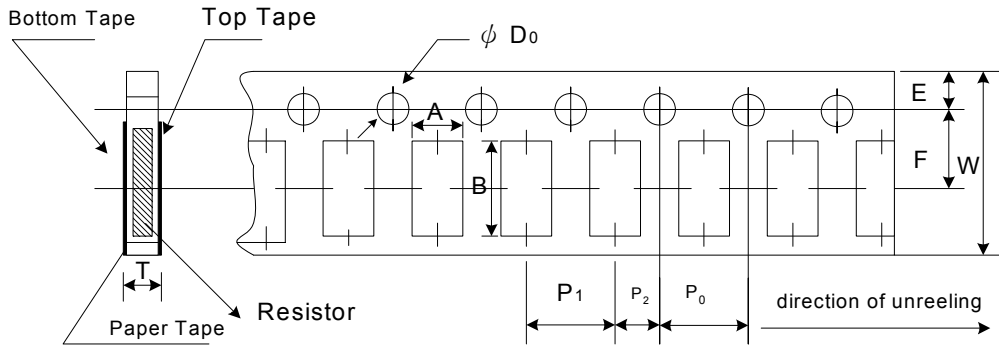

Unit: mm

Codes	A	B	W	E	F	P ₀	P ₁	P ₂	ΦD ₀	T
PR02	0.70±0.05	1.16±0.05	8.00±0.10	1.75±0.05	3.5±0.05	4.00±0.10	2.00±0.05	2.00±0.05	1.55±0.05	0.40±0.03
PR03	1.10±0.05	1.90±0.05	8.00±0.10	1.75±0.05	3.5±0.05	4.00±0.10	4.00±0.10	2.00±0.05	1.55±0.05	0.60±0.03
PR05	1.60±0.05	2.37±0.05	8.00±0.10	1.75±0.05	3.5±0.05	4.00±0.10	4.00±0.10	2.00±0.05	1.55±0.05	0.75±0.05
PR06	2.00±0.05	3.55±0.05	8.00±0.10	1.75±0.05	3.5±0.05	4.00±0.10	4.00±0.10	2.00±0.05	1.55±0.05	0.75±0.05

Emboss Plastic Tape Specifications

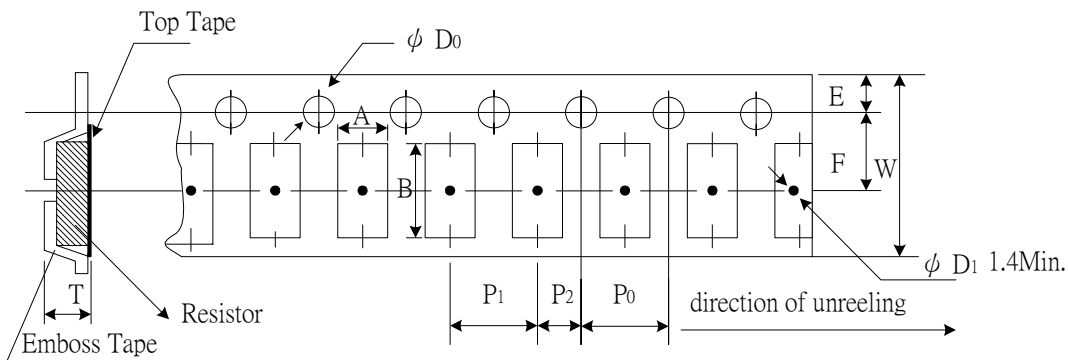

Unit: mm

Codes	A	B	W	E	F	P ₀	P ₁	P ₂	ΦD ₀	T
PR10	2.85±0.10	5.45±0.10	12.0±0.10	1.75±0.10	5.5±0.05	4.00±0.05	4.00±0.10	2.00±0.05	1.50±0.10	1.00±0.20
PR12	3.40±0.10	6.65±0.10	12.0±0.10	1.75±0.10	5.5±0.05	4.00±0.05	4.00±0.10	2.00±0.05	1.50±0.10	1.00±0.20

Recommend Land Pattern

Unit : mm

Codes	A	B	C
PR12	4.90	1.60	3.10±0.2
PR10	3.60	1.40	2.50±0.2
PR06	2.00	1.15	1.70±0.2
PR05	1.00	1.00	1.35±0.2
PR03	0.80	1.00	0.90±0.2
PR02	0.50	0.50	0.60±0.2

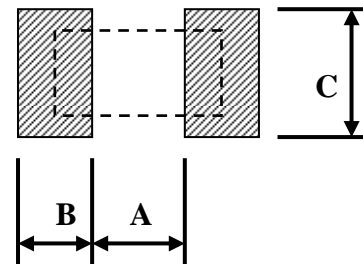

Environmental Characteristics

Test Item	Specification		Test Method
	Size 0603 / 0805 1206 / 2010 2512	Size 0402	
Short Time Overload	$\leq \pm 0.02\%$	$\leq \pm 0.1\%$	RCWV*2.5 or Max Overloading Voltage · 2 seconds
Thermal Shock	$\leq \pm 0.02\%$	$\leq \pm 0.1\%$	MIL-STD-202F Method 107G -55°C~150°C, 100 cycles
Load Life	$\leq \pm 0.05\%$	$\leq \pm 0.25\%$	MIL-STD-202F Method 108A RCWV · 70°C · 1.5 hours ON · 0.5 hours OFF, total 1000~1048 hours
Humidity (Steady State)	$\leq \pm 0.05\%$	$\leq \pm 0.5\%$	MIL-STD-202F Method 103B 40°C , 90~95%RH,RCWV 1.5 hours ON,0.5 hours OFF, total 1000~1048 hours
Resistance to Dry Heat	$\leq \pm 0.05\%$	$\leq \pm 0.5\%$	JIS-C-5202-7.2 1000 hours @ +155°C without load
Resistance to Soldering Heat	$\leq \pm 0.02\%$	$\leq \pm 0.1\%$	MIL-STD-202F Method 210E 260±5°C, 10±1 seconds
Solderability	95%min coverage		MIL-STD-202F Method 208H 245°C±5°C, 2±0.5 (sec)

* Storage Temperature :25±3°C; Humidity <80%RH