

Thick Film Chip Resistor—CR Series

Features

— Smaller Size of 0201 is Available



Construction

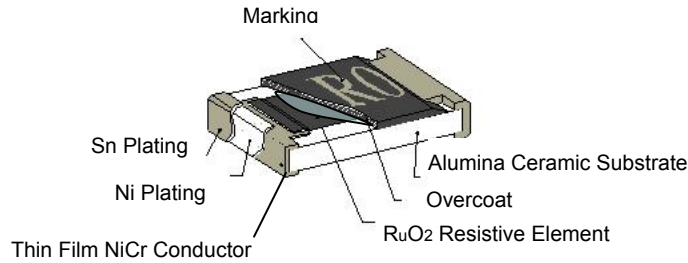

Part Numbering

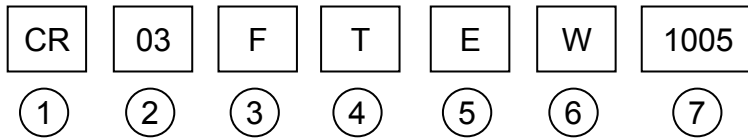

① Product Type

Product Type	
CR	Thick Film Chip Resistor

② Dimensions (L×W)

Codes	Dimensions (L×W)	EIA
CR01	0.6×0.30mm	0201
CR02	1.0×0.50mm	0402
CR03	1.6×0.80mm	0603
CR05	2.0×1.25mm	0805
CR06	3.1×1.55mm	1206
CR12	3.1×2.5 mm	1210
CR10	5.0×2.5 mm	2010
CR25	6.3×3.2 mm	2512

③ Resistance Tolerance

Codes	Resistance Tolerance
F	±1%
J	±5%

④ Packaging

Code	Type
T	Taping Reel

⑤ TCR

Codes	Type
E	±100PPM/°C
F	±200PPM/°C
-	No specified

⑥ High Power Rating

Code	Type
	Standard
W	1/8W
V	1/4W
U	1/2W
Q	3/4W
T	1W
S	2W

⑦ Resistance

Codes	Type
1000	100Ω
2201	2200Ω
1002	10000Ω
4992	49900Ω
1003	100000Ω

Dimensions

Unit: mm

Size	Codes	L	W	T	D1	D2
0201	CR01	0.6±0.03	0.30±0.03	0.23±0.03	0.15±0.05	0.15±0.05
0402	CR02	1.0±0.10	0.50±0.05	0.35±0.05	0.20±0.10	0.25±0.10
0603	CR03	1.6±0.15	0.80±0.10	0.45±0.10	0.30±0.20	0.30±0.20
0805	CR05	2.0±0.15	1.25±0.10	0.50±0.10	0.35±0.20	0.40±0.20
1206	CR06	3.1±0.10	1.55±0.10	0.55±0.10	0.45±0.20	0.40±0.20
1210	CR12	3.1±0.10	2.55±0.10	0.55±0.10	0.50±0.20	0.50±0.20
2010	CR10	5.0±0.20	2.50±0.20	0.55±0.10	0.60±0.20	0.50±0.20
2512	CR25	6.3±0.20	3.20±0.20	0.55±0.10	0.60±0.20	0.50±0.20

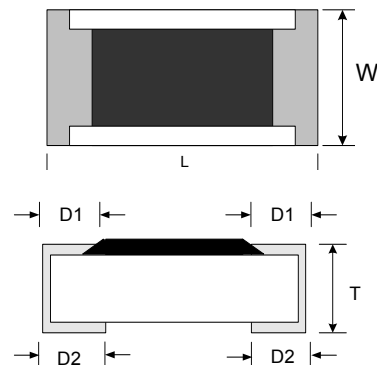

Standard Electrical Specifications

Item Type	Power Rating at 70°C	Operating Temp. Range	Max Operating Voltage	Max Overloading Voltage	Resistance Tolerance		Resistance Range	TCR (PPM/°C)
					-	±1%,±5%		
CR01 (0201)	1/20W	-55 ~ +125°C	15V	30V	-	±1%,±5%	0Ω	-
					E96	±1%	10Ω~1MΩ	200
					E24	±5%		
CR02 (0402)	1/16W	-55 ~ +125°C	50V	100V	-	±1%,±5%	0Ω	-
					E96 E24	±0.5%	1.1MΩ~10MΩ	200
±1%	1Ω~9.76Ω 10Ω~1MΩ 1.1MΩ~10MΩ 11MΩ~20MΩ 22MΩ~39MΩ	200 100 200 200 400						
E24			±5%					
			CR12 (1210)	1/3W	-55 ~ +155°C	200V	400V	-
CR10 (2010)	3/4W	-55 ~ +155°C	200V	400V	-	±0.5%	1.1MΩ~10MΩ	200
CR25 (2512)	1W	-55 ~ +155°C	200V	400V	E96 E24	±1%	1Ω~9.76Ω 10Ω~1MΩ 1.1MΩ~10MΩ 11MΩ~20MΩ	200 100 200 200

High Power Rating Electrical Specifications

Item Type	Power Rating at 70°C	Operating Temp. Range	Max Operating Voltage	Max Overloading Voltage	Resistance Tolerance		Resistance Range	TCR (PPM/°C)
					-	±1%		
CR03 (0603)	1/8W	-55 ~ +125°C	50V	100V	E96 E24	±1%	1Ω~9.76Ω 10Ω~1MΩ 1.1MΩ~10MΩ	200 100 200
CR05 (0805)	1/4W	-55 ~ +155°C	150V	300V				
CR06 (1206)	1/2W	-55 ~ +155°C	200V	400V				
CR12 (1210)	1/2 3/4W	-55 ~ +155°C	200V	400V	E24	±5%	1.1MΩ~10MΩ	200
CR10 (2010)	1W	-55 ~ +155°C	200V	400V				
CR25 (2512)	2W	-55 ~ +155°C	250V	500V				

Operating Voltage $V=\sqrt{P \cdot R}$

Overload Voltage $V=2.5 \cdot \sqrt{P \cdot R}$

Packaging

Reel Specifications & Packaging Quantity

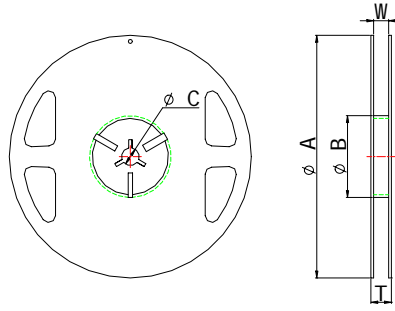

Unit: mm

Series	Packaging	ΦA	ΦB	ΦC	W	T	Paper Tape (EA)	Embossed Tape (EA)
CR01		180+0/-3	60+1/-0	13.0±0.2	9.0±0.3	11.4±1.0	10,000	—
CR02		180+0/-3	60+1/-0	13.0±0.2	9.0±0.3	11.4±1.0	10,000	—
CR03		180+0/-3	60+1/-0	13.0±0.2	9.0±0.3	11.4±1.0	5,000	—
CR05		180+0/-3	60+1/-0	13.0±0.2	9.0±0.3	11.4±1.0	5,000	—
CR06		180+0/-3	60+1/-0	13.0±0.2	9.0±0.3	11.4±1.0	5,000	—
CR12		180+0/-3	60+1/-0	13.0±0.2	9.0±0.3	11.4±1.0	5,000	—
CR10		180+0/-3	60+1/-0	13.0±0.2	13.5±0.5	15.4±1.0	—	4000
CR25		180+0/-3	60+1/-0	13.0±0.2	13.5±0.5	15.4±1.0	—	4000

Paper Tape Specifications

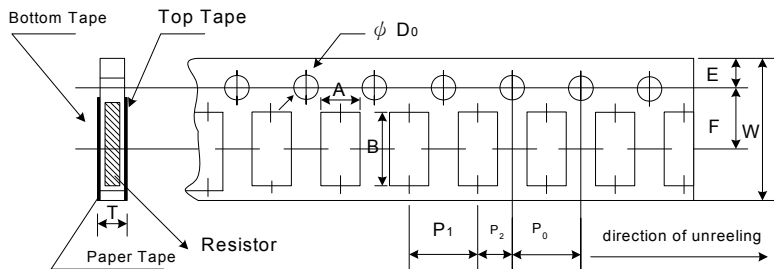

Unit: mm

Series	A	B	W	F	E	P ₁	P ₂	P ₀	ΦD ₀	T
CR01	0.45±0.10	0.75±0.1	8.0±0.2	3.50±0.05	1.75±0.01	2.00±0.01	2.00±0.05	4.00±0.10	1.50+0.1,-0	0.35±0.1
CR02	0.65±0.15	1.15±0.2	8.0±0.2	3.50±0.05	1.75±0.01	2.00±0.01	2.00±0.05	4.00±0.10	1.50+0.1,-0	0.45±0.1
CR03	1.10±0.10	1.90±0.1	8.0±0.2	3.50±0.05	1.75±0.01	4.00±0.01	2.00±0.05	4.00±0.10	1.50+0.1,-0	0.85±0.1
CR05	1.60±0.15	2.40±0.2	8.0±0.2	3.50±0.05	1.75±0.01	4.00±0.01	2.00±0.05	4.00±0.10	1.50+0.1,-0	0.85±0.1
CR06	2.00±0.15	3.60±0.2	8.0±0.2	3.50±0.05	1.75±0.01	4.00±0.01	2.00±0.05	4.00±0.10	1.50+0.1,-0	0.85±0.1
CR12	2.80±0.10	3.50±0.2	8.0±0.2	3.50±0.05	1.75±0.01	4.00±0.01	2.00±0.05	4.00±0.10	1.50+0.1,-0	0.85±0.1

Emboss Plastic Tape Specifications

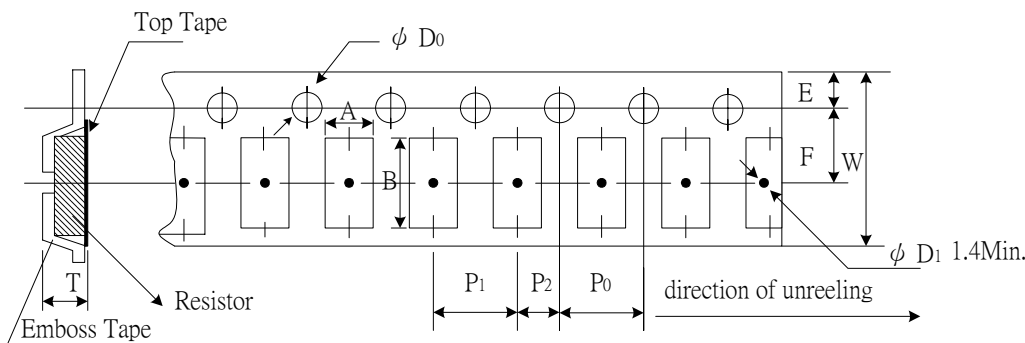

Unit: mm

Series	A	B	W	F	E	P ₁	P ₂	P ₀	ΦD ₀	T
CR10	2.8±0.20	5.5±0.20	12.0±0.3	5.5±0.05	1.75±0.1	4.00±0.1	2.00±0.05	4.00±0.10	1.50+0.25,-0	1.2 ⁺⁰
CR25	3.6±0.20	6.9±0.20	12.0±0.3	5.5±0.05	1.75±0.1	4.00±0.1	2.00±0.05	4.00±0.10	1.50+0.25,-0	1.2 ⁺⁰

Environmental Characteristics

Item	Specification	Test Method
Temperature Coefficient of Resistance	As Spec.	MIL-STD-202F Method 304 +25/-55/+25/+125/+25°C
Thermal Shock	±1.0%	MIL-STD-202F, Method 107 -55°C~150°C, 5 cycles
Short Time Overload	±2.0%	JIS-C-5202-5.5 RCWV*2.5 or Max Overloading Voltage · 5 seconds
Resistance to Dry Heat	±2.0%	JIS-C-5202-7.2 96 hours @ +155°C without load
Load Life	±3.0%	MIL-STD-202F 108A RCWV, 70°C, 1.5 hours on, 0.5 hours off total 1000~1048 hours
Resistance to Soldering Heat	±1.0%	MIL-STD-202F Method 210E 260±5°C, 10±1 seconds
Humidity (Steady State)	±2.0%	MIL-STD-202F Method 103B 40°C , 90~95%RH,RCWV 1.5 hours ON,0.5 hours OFF, total 1000~1048 hours
Low Temperature Operation	±1.0%	JIS-C-5202-7.1 1 hours,-65°C, followed by 45minutes of RCWV
Bending Strength	±1.0%	JIS-C-5202-6.1.4 Bending Amplitude 3mm for 10 seconds
Solderability	95%min coverage	MIL-STD-202F Method 208H 245°C±5°C, 5±0.5 (sec)

* Storage Temperature :25±3°C; Humidity <80%RH