



# CPTC Thermistor

## PRODUCT DATA

### ■ Temperature Sensor

#### ● Features

1. Small size
2. Very fast reaction time
3. Wide range of protection temperatures, from 60°C to 180°C
4. No need reset supply after protection
5. Stable over along life

#### ● Recommended Applications

1. Electrical equipment (Electrical machinery, Transformer)

#### ● Approvals



\* UL 1434 Recognized(File#E138827)

\* cUL Recognized(File#E138827)



\* CQC Certificate No.CQC03001008129 & CQC03001008130



#### ● Dimensions

PTL Series

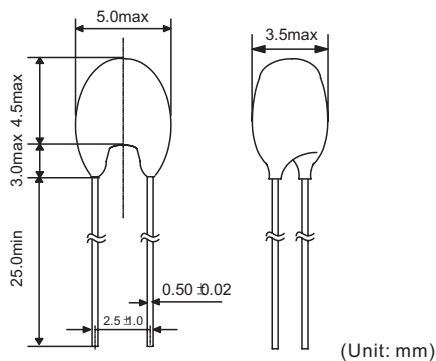



## ● Characteristics

### PTL Series

Part No.	Curie Temperature	Sensing Temperature	Resistance Value			Maximum Voltage	Maximum Current
	T <sub>c</sub> (°C)	T <sub>s</sub> (°C)	25°C (Ω)	T <sub>s</sub> -5°C (Ω)	T <sub>s</sub> +5°C (Ω)	V <sub>max</sub> (V)	I <sub>max</sub> (mA)
PTLS2101□P4**	40±10	55	100 max.	330 max.	470 min.	30	100
PTLS2101□P5**	50±10	65					
PTLS2101□P6**	60±10	75					
PTLS2101□P7**	70±10	85					
PTLS2101□P8**	80±10	95					
PTLS2101□P9**	90±10	105					
PTLS2331□P4**	40±10	55	330 max.	1500 max.	2200 min.		
PTLS2331□P5**	50±10	65					
PTLS2331□P6**	60±10	75					
PTLS2331□P7**	70±10	85					
PTLS2331□P8**	80±10	95					
PTLS2331□P9**	90±10	105					
PTLS2331□A0**	100±10	115					

Note1: □=Tolerance of R<sub>25</sub>

Note2: \*\*= Maximum Voltage: 16V or 30V.

### PTL-B02/03 Series

Part No.	Curie Temperature	Sensing Temperature	Resistance Value (Ω)					Maximum Voltage	Maximum Current
	T <sub>c</sub> (°C)	T <sub>s</sub> (°C)	25°C (Ω)	T <sub>s</sub> -5°C (Ω)	T <sub>s</sub> +5°C (Ω)	T <sub>s</sub> +15°C (Ω)	T <sub>s</sub> +23°C (Ω)	V <sub>max</sub> (V)	I <sub>max</sub> (mA)
PTLS2101□P4**B02	40±10	60	100 max.	570 max.	570 min.	—	10K min.	30	100
PTLS2101□P5**B02	50±10	70							
PTLS2101□P6**B02	60±10	80							
PTLS2101□P7**B03	70±10	90		550 max.	1330 min.	4000 min.	—		
PTLS2101□P8**B03	80±10	100							
PTLS2101□P9**B03	90±10	110							
PTLS2101□A0**B03	100±10	120							
PTLS2101□A1**B03	110±10	130							
PTLS2101□A2**B03	120±10	140							
PTLS2101□A3**B03	130±10	150							
PTLS2101□A4**B03	140±10	160							
PTLS2101□A5**B03	150±10	170							
PTLS2101□A6**B03	160±10	180							

Note1: □=Tolerance of R<sub>25</sub>

Note2: \*\*= Maximum Voltage: 16V or 30V.



● **Reliability Test**

Item	Test Condition / Methods	Standard
Resistance to Soldering Heat	Temperature: 350 ± °C Duration: 3~4 s	IEC60068-2-20 Test T <sub>B</sub>
Robustness of Termination	Tensile, bending and torsion tests as appropriate to type termination	IEC60068-2-21
Rapid Change of Temperature	T <sub>A</sub> =LCT T <sub>B</sub> =UCT Number of cycles:5 Duration: 30 min	IEC60068-2-14 Test N <sub>a</sub>
Vibration	Frequency :10-55 Hz h= 0.75 min Duration: 6 h	IEC 60068-2-6 Test F <sub>C</sub>
Shock	Pulse shape: half-sine Acceleration: 50m/s <sup>2</sup> Pulse duration: 30 ms	IEC 60068-2-27 Test E <sub>a</sub>
Climatic Sequence	Dry heat :T= 40°C, 24hrs , 20%Rh Damp heat first cycle: T=40°C 95% R h Cold: T=0°C, 2hrs Damp heat 5 cycles	IEC 60068-2-2 Test B <sub>a</sub> IEC 60068-2-30 Test D <sub>b</sub> IEC 60068-2-1 Test A <sub>a</sub>
Thermal Time Constant by Cooling	63.2% of temperature excess	IEC 60738-1
Temperature Coefficient of Resistance	$\alpha_T = \ln(R_{Tc+25}/R_{Tc+10}) / 15$ R <sub>Tc</sub> =2R <sub>min</sub>	IEC 60738-1
Dissipation Factor at V <sub>max</sub>	Voltage: V <sub>max</sub> Current: <I <sub>max</sub>	IEC 60738-1
Endurance at Upper Category Temperature	Temperature: UCT Duration: 1000 hrs	IEC 60738-1
Endurance at Maximum Operating Temperature and Maximum Voltage	Voltage: V <sub>max</sub> Temperature: UCT Current: <I <sub>max</sub> Duration: 1000 hrs	IEC 60738-1
Damp Heat Steady State	Temperature: 40 ±5°C Relative humidity of air: 95~98%Rh Duration: 1000 hrs	IEC 60068-2-3 Test C <sub>a</sub>