



# CPTC Thermistor

## PRODUCT DATA

### ■ Overload Protection

#### ● Features

1. PPD type are naked
2. PPL Type are leaded
3. Low, medium and high voltage ratings
4. Low resistance
5. Small size
6. No need to reset supply after overload
7. No noise generated
8. Stable over a long time

#### ● Recommended Applications

1. Telecommunications (Program-controller)
2. Electrical equipment (Electrical machinery, Transformer)

#### ● Approvals



- \* UL 1434 Recognized (File#E138827)
- \* cUL Recognized (File#E138827)



- \* TUV Certificate No.R50025585



- \* CQC Certificate No.CQC03001008123 & CQC03001008124



#### ● Dimensions

PPL Series

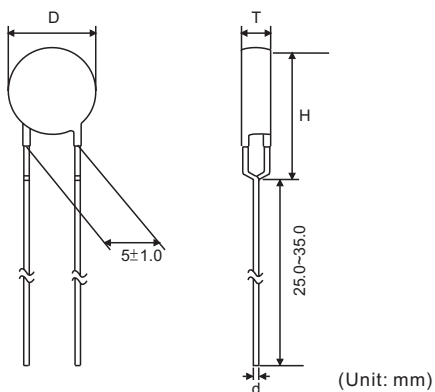



## ● Characteristics

### PPL Series

Part No.	Curie Temperature	Nominal Zero-power Resistance	Trip Current at 25°C	Non-operating Current at 25°C	Voltage	Maximum Current	Dimensions				
	T <sub>c</sub> (°C)	R <sub>25</sub> (Ω)	I <sub>t</sub> (mA)	I <sub>N</sub> (mA)	V <sub>R</sub> (V)	I <sub>max</sub> (A)	D <sub>max</sub> (mm)	T <sub>max</sub> (mm)	d±0.02(mm)	H <sub>max</sub> (mm)	
PPL04130 A212	120±10	13	240	120	12	0.7	6.5	3.5	0.6	10.5	
PPL054R6 A212		4.6	500	250	12	1.0	7.0	3.5	0.6	10.5	
PPL081R8 A212		1.8	900	450	12	3.0	10	3.5	0.6	13.5	
PPL091R0 A212		1.0	1120	410	12	3.0	11	3.5	0.6	14.5	
PPL091R4 A212		1.4	1060	350	12	3.0	11	3.5	0.6	14.5	
PPL101R2 A212		1.2	1200	600	12	4.3	12	3.5	0.6	15.5	
PPL120R8 A212		0.8	1700	850	12	5.5	14	3.5	0.6	17.5	
PPL140R4 A212		0.4	2700	950	12	5.0	16	3.5	0.6	19.5	
PPL140R5 A212		0.5	2450	870	12	5.0	16	3.5	0.6	19.5	
PPL140R9 A212		0.9	1210	430	12	5.0	16	3.5	0.6	19.5	
PPL160R5 A212		0.5	2600	1300	12	8.0	17.5	5.0	0.6	20.5	
PPL200R3 A212		0.3	3600	1800	12	10.0	22	5.0	0.6	25.5	
PPL077R0 P824		80±10	7.0	360	90	24	2.0	9.0	3.5	0.6	12.5
PPL07100 P824			10	330	80	24	2.0	9.0	3.5	0.6	12.5
PPL083R0 P824	3.0		570	145	24	2.0	10	3.5	0.6	13.5	
PPL092R0 P824	2.0		720	185	24	2.0	11	3.5	0.6	14.5	
PPL084R7 A224	120±10	4.7	700	295	24	3.5	10	3.5	0.6	13.5	
PPL103R9 A224		3.9	800	340	24	4.3	12	3.5	0.6	15.5	
PPL143R3 A224		3.3	980	420	24	5.0	16	3.5	0.6	19.5	
PPL056R0 A424		6.0	540	270	24	2.5	7.0	5.0	0.6	10.5	
PPL05130 A424	140±10	13	360	180	24	1.7	7.0	5.0	0.6	10.5	
PPL073R0 A424		3.0	820	410	24	4.5	9.0	5.0	0.6	12.5	
PPL075R0 A424		5.0	640	320	24	3.5	9.0	5.0	0.6	12.5	
PPL081R9 A424		1.9	1080	540	24	6.0	10	5.0	0.6	13.5	
PPL082R5 A424		2.5	940	470	24	5.0	10	5.0	0.6	13.5	
PPL101R3 A424		1.3	1400	700	24	8.0	12	5.0	0.6	15.5	
PPL101R7 A424		1.7	1220	610	24	7.0	12	5.0	0.6	15.5	
PPL120R9 A424		0.9	1840	920	24	11.0	14	5.0	0.6	17.5	
PPL121R1 A424		1.1	1660	830	24	10.0	14	5.0	0.6	17.5	
PPL160R5 A424		0.5	2780	1390	24	16.0	17.5	5.0	0.6	20.5	
PPL160R7 A424		0.7	2340	1170	24	13.5	17.5	5.0	0.6	20.5	
PPL200R3 A424		0.3	4100	2050	24	23.0	22	5.0	0.6	25.5	
PPL200R4 A424		0.4	3540	1770	24	20.0	22	5.0	0.6	25.5	
PPL06150 P842		80±10	15	230	60	42	1.5	8.0	4.0	0.6	11.5
PPL06220 P842	22		220	45	42	1.1	8.0	4.0	0.6	11.5	
PPL06330 P842	33		180	40	42	0.9	8.0	4.0	0.6	11.5	
PPL06470 P842	47		150	35	42	0.7	8.0	4.0	0.6	11.5	
PPL06560 P842	56		140	30	42	0.7	8.0	4.0	0.6	11.5	
PPL03510 A642	160±10	51	165	55	42	0.6	5.0	4.0	0.5	8.5	
PPL05240 A642		24	285	95	42	1.0	7.0	4.0	0.6	10.5	
PPL089R1 A642		9.1	525	175	42	3.0	10	4.0	0.6	13.5	
PPL095R1 A642		5.1	870	290	42	4.5	11	4.0	0.6	14.5	
PPL113R6 A642		3.6	1080	360	42	5.0	13.5	4.0	0.6	16.5	
PPL04420 A248	120±10	42	210	105	48	0.75	6.5	5.0	0.6	10.5	
PPL04600 A248		60	180	90	48	0.6	6.5	5.0	0.6	10.5	
PPL04900 A248		90	140	70	48	0.46	6.5	5.0	0.6	10.5	
PPL06220 A248		22	310	155	48	1.3	8.0	5.0	0.6	11.5	
PPL06320 A248		32	260	130	48	0.95	8.0	5.0	0.6	11.5	
PPL08180 A248		18	390	195	48	1.6	10	5.0	0.6	13.5	
PPL10120 A248		12	460	230	48	2.2	12	5.0	0.6	15.5	
PPL126R5 A248		6.5	700	350	48	4.0	14	5.0	0.6	17.5	
PPL129R0 A248		9.0	570	285	48	2.9	14	5.0	0.6	17.5	
PPL134R3 A248		4.3	850	425	48	6.3	15	5.0	0.6	18.5	
PPL162R6 A248		2.6	1210	605	48	12	17.5	5.0	0.6	20.5	
PPL163R8 A248		3.8	1010	505	48	7.3	17.5	5.0	0.6	20.5	
PPL201R6 A248		1.6	1750	870	48	18	22	5.0	0.6	25.5	
PPL202R2 A248		2.2	1450	725	48	14	22	5.0	0.6	25.5	
PPL05250 A448	140±10	25	260	130	48	1.2	7.0	5.0	0.6	10.5	
PPL05500 A448		50	188	94	48	0.8	7.0	5.0	0.6	10.5	
PPL03510 A263		51	165	55	63	0.7	5.0	4.0	0.5	8.5	
PPL05240 A263		24	270	90	63	1.0	7.0	4.0	0.6	10.5	
PPL089R1 A263	120±10	9.1	480	160	63	3.0	10	4.0	0.6	13.5	
PPL095R1 A263		5.1	850	280	63	4.5	11	4.0	0.6	14.5	
PPL113R6 A263		3.6	960	320	63	5.0	13.5	4.0	0.6	16.5	
PPL152R4 A263		2.4	1400	460	63	7.5	17.5	4.0	0.6	20.5	
PPL201R7 A263		1.7	1400	700	63	10	22	5.0	0.6	25.5	
PPL04620 A363		62	130	85	63	0.7	6.5	5.0	0.6	10.5	
PPL05200 A363		20	240	150	63	1.0	7.0	5.0	0.6	10.5	
PPL088R0 A363	130±10	8.0	380	250	63	3.0	10	5.0	0.6	13.5	
PPL104R9 A363		4.9	500	320	63	4.3	12	5.0	0.6	15.5	
PPL123R3 A363		3.3	690	450	63	5.5	14	5.0	0.6	17.5	
PPL162R2 A363		2.2	1100	700	63	8.0	17.5	5.0	0.6	20.5	
PPL201R2 A363		1.2	1500	1000	63	10.0	22	5.0	0.6	25.5	
PPL126R8 A2A1		120±10	6.8	660	290	110	1.0	14	4.5	0.6	17.5
PPL12100 A2A1	10		500	220	110	1.0	14	4.5	0.6	17.5	
PPL164R7 A2A1	4.7		900	390	110	2.0	17.5	5.0	0.6	20.5	
PPL05280 A4A1	28		260	130	110	0.6	7.0	5.0	0.6	10.5	
PPL05400 A4A1	40		220	110	110	0.5	7.0	5.0	0.6	10.5	
PPL05550 A4A1	55		186	93	110	0.45	7.0	5.0	0.6	10.5	
PPL05121 A4A1	120		130	65	110	0.3	7.0	5.0	0.6	10.5	
PPL05241 A4A1	240		94	47	110	0.2	7.0	5.0	0.6	10.5	
PPL07120 A4A1	12		420	210	110	1.4	9.0	5.0	0.6	12.5	
PPL07190 A4A1	19		340	170	110	1.0	9.0	5.0	0.6	12.5	
PPL088R0 A4A1	8.0	540	270	110	2.2	10	5.0	0.6	13.5		



Part No.	Curie Temperature	Nominal Zero-power Resistance	Trip Current at 25°C	Non-operating Current at 25°C	Voltage	Maximum Current	Dimensions			
	T <sub>c</sub> (°C)	R <sub>25</sub> (Ω)	I <sub>t</sub> (mA)	I <sub>N</sub> (mA)	V <sub>R</sub> (V)	I <sub>max</sub> (A)	D <sub>max</sub> (mm)	T <sub>max</sub> (mm)	d±0.02(mm)	H <sub>max</sub> (mm)
PPL089R4 A4A1	140±10	9.4	500	250	110	2.0	10	5.0	0.6	13.5
PPL105R3 A4A1		5.3	720	360	110	3.5	12	5.0	0.6	15.5
PPL106R7 A4A1		6.7	640	320	110	3.0	12	5.0	0.6	15.5
PPL123R8 A4A1		3.8	900	450	110	5.0	14	5.0	0.6	17.5
PPL124R6 A4A1		4.6	820	410	110	4.5	14	5.0	0.6	17.5
PPL162R1 A4A1		2.1	1420	710	110	8.5	17.5	5.0	0.6	20.5
PPL162R9 A4A1		2.9	1200	600	110	7.2	17.5	5.0	0.6	20.5
PPL201R3 A4A1		1.3	2000	1000	110	13	22	5.0	0.6	25.5
PPL201R7 A4A1		1.7	1760	880	110	11	22	5.0	0.6	25.5
PPL03151 P8B2		80±10	150	60	15	220	0.3	5.0	5.0	0.5
PPL05680 P8B2	68		110	35	220	0.5	7.0	5.0	0.6	10.5
PPL07360 P8B2	36		180	45	220	0.7	9.0	5.0	0.6	12.5
PPL08220 P8B2	22		195	65	220	1.2	10	5.0	0.6	13.5
PPL09150 P8B2	15		270	90	220	1.5	11	5.0	0.6	14.5
PPL09180 P8B2	18		225	75	220	1.3	11	5.0	0.6	14.5
PPL11100 P8B2	10		360	120	220	2.3	13.5	5.0	0.6	16.5
PPL155R6 P8B2	5.6		540	180	220	4.5	17.5	5.0	0.6	20.5
PPL203R9 P8B2	3.9		720	240	220	7.0	22	5.0	0.6	25.5
PPL242R7 P8B2	2.7		1050	350	220	9.5	26	5.0	0.8	29.5
PPL03151 A2B2	120±10	150	90	30	220	0.3	5.0	5.0	0.5	8.5
PPL04381 A2B2		380	70	35	220	0.25	6.5	5.0	0.6	10.5
PPL04561 A2B2		560	60	30	220	0.2	6.5	5.0	0.6	10.5
PPL04851 A2B2		850	50	25	220	0.16	6.5	5.0	0.6	10.5
PPL04122 A2B2		1200	40	20	220	0.13	6.5	5.0	0.6	10.5
PPL04192 A2B2		1900	30	15	220	0.11	6.5	5.0	0.6	10.5
PPL05750 A2B2		75	150	50	220	0.5	7.0	5.0	0.6	10.5
PPL05181 A2B2		180	70	29	220	0.3	7.0	5.0	0.6	10.5
PPL06121 A2B2		120	100	35	220	0.4	8.0	5.0	0.6	11.5
PPL06201 A2B2		200	100	50	220	0.35	8.0	5.0	0.6	11.5
PPL06281 A2B2		280	90	45	220	0.29	8.0	5.0	0.6	11.5
PPL07560 A2B2		56	200	60	220	0.8	9.0	5.0	0.6	12.5
PPL07820 A2B2		82	160	60	220	0.5	9.0	5.0	0.6	12.5
PPL08240 A2B2		24	300	100	220	1.1	10	5.0	0.6	13.5
PPL08360 A2B2		36	250	85	220	1.0	10	5.0	0.6	13.5
PPL08390 A2B2		39	240	75	220	1.0	10	5.0	0.6	13.5
PPL08500 A2B2		50	210	105	220	0.73	10	5.0	0.6	13.5
PPL08510 A2B2		51	195	65	220	1.0	10	5.0	0.6	13.5
PPL08620 A2B2		62	165	55	220	1.0	10	5.0	0.6	13.5
PPL08720 A2B2		72	180	90	220	0.6	10	5.0	0.6	13.5
PPL09160 A2B2		16	450	150	220	1.5	11	5.0	0.6	14.5
PPL10150 A2B2		15	280	140	220	1.5	12	5.0	0.6	15.5
PPL10260 A2B2		26	310	155	220	1.1	12	5.0	0.6	15.5
PPL10390 A2B2		39	250	100	220	1.2	12	5.0	0.6	15.5
PPL11110 A2B2		11	600	200	220	2.2	13.5	5.0	0.6	16.5
PPL12100 A2B2		10	650	230	220	2.3	14	5.0	0.6	17.5
PPL12140 A2B2		14	460	230	220	1.7	14	5.0	0.6	17.5
PPL12200 A2B2		20	390	195	220	1.3	14	5.0	0.6	17.5
PPL12270 A2B2		27	350	120	220	1.5	14	5.0	0.6	17.5
PPL14180 A2B2		18	450	180	220	1.8	16	5.0	0.6	19.5
PPL156R2 A2B2	6.2	960	320	220	4.0	17.5	5.0	0.6	20.5	
PPL168R0 A2B2	8.0	700	350	220	2.5	17.5	5.0	0.6	20.5	
PPL203R6 A2B2	3.6	1380	460	220	7.0	22	5.0	0.6	25.5	
PPL205R0 A2B2	5.0	1010	505	220	3.6	22	5.0	0.6	25.5	
PPL207R0 A2B2	7.0	850	425	220	3.0	22	5.0	0.6	25.5	
PPL242R4 A2B2	2.4	1980	660	220	10.5	26	5.0	0.8	29.5	
PPL04161 A3B2	130±10	160	90	55	220	0.2	6.5	5.0	0.6	10.5
PPL05500 A3B2		50	150	100	220	0.4	7.0	5.0	0.6	10.5
PPL08250 A3B2		25	230	140	220	1.0	10	5.0	0.6	13.5
PPL10130 A3B2		13	320	200	220	1.5	12	5.0	0.6	15.5
PPL129R0 A3B2		9.0	500	330	220	2.2	14	5.0	0.6	17.5
PPL165R0 A3B2		5.0	680	450	220	4.1	17.5	5.0	0.6	20.5
PPL203R5 A3B2		3.5	980	650	220	7.0	22	5.0	0.6	25.5
PPL03181 A4B2		180	90	30	220	0.3	5.0	5.0	0.5	8.5
PPL05560 A4B2		56	190	95	220	0.6	7.0	5.0	0.6	10.5
PPL05750 A4B2		75	180	60	220	0.4	7.0	5.0	0.6	10.5
PPL05850 A4B2	85	152	76	220	0.55	7.0	5.0	0.6	10.5	
PPL05121 A4B2	120	126	63	220	0.45	7.0	5.0	0.6	10.5	
PPL05261 A4B2	260	78	39	220	0.3	7.0	5.0	0.6	10.5	
PPL05501 A4B2	500	56	28	220	0.2	7.0	5.0	0.6	10.5	
PPL05122 A4B2	1200	38	19	220	0.14	7.0	5.0	0.6	10.5	
PPL05192 A4B2	1900	30	15	220	0.11	7.0	5.0	0.6	10.5	
PPL05302 A4B2	3000	22	11	220	0.08	7.0	5.0	0.6	10.5	
PPL07290 A4B2	140±10	29	280	140	220	0.8	9.0	5.0	0.6	12.5
PPL07480 A4B2		48	220	110	220	0.65	9.0	5.0	0.6	12.5
PPL08180 A4B2		18	380	190	220	1.0	10	5.0	0.6	13.5
PPL08220 A4B2		22	340	170	220	0.9	10	5.0	0.6	13.5
PPL08240 A4B2		24	330	110	220	1.0	10	5.0	0.6	13.5
PPL09160 A4B2		16	450	150	220	1.5	11	5.0	0.6	14.5
PPL10120 A4B2		12	500	250	220	1.5	12	5.0	0.6	15.5
PPL10170 A4B2		17	420	210	220	1.3	12	5.0	0.6	15.5
PPL119R1 A4B2		9.1	660	220	220	2.5	13.5	5.0	0.6	16.5
PPL128R4 A4B2		8.4	640	320	220	2.2	14	5.0	0.6	17.5
PPL12110 A4B2	11	560	280	220	1.8	14	5.0	0.6	17.5	
PPL164R4 A4B2	4.4	980	490	220	3.5	17.5	5.0	0.6	20.5	



Part No.	Curie Temperature	Nominal Zero-power Resistance	Trip Current at 25°C	Non-operating Current at 25°C	Voltage	Maximum Current	Dimensions				Remark
	Tc (°C)						R <sub>25</sub> (Ω)	I <sub>t</sub> (mA)	I <sub>N</sub> (mA)	V <sub>R</sub> (V)	
PPL155R1□A4B2	140±10	5.1	1050	350	220	4.5	17.5	5.0	0.6	20.5	—
PPL166R6□A4B2		6.6	800	400	220	3.0	17.5	5.0	0.6	20.5	
PPL202R8□A4B2		2.8	1400	700	220	5.5	22	5.0	0.6	25.5	
PPL203R6□A4B2		3.6	1400	470	220	5.0	22	5.0	0.6	25.5	
PPL204R0□A4B2		4.0	1180	590	220	4.5	22	5.0	0.6	25.5	
PPL07220□A0B5	100±10	22	260	100	250	0.5	9.0	6.0	0.6	12.5	
PPL10390□A2B7	120±10	39	250	100	270	1.2	12	5.0	0.6	15.5	
PPL12270□A2B7		27	350	120	270	1.5	14	5.0	0.6	17.5	
PPL10820□A2C0		82	250	80	300	0.5	12	5.5	0.6	15.5	
PPL10151□A2C0		150	150	60	300	0.3	12	5.5	0.6	15.5	
PPL10351□A2C0		350	100	35	300	0.3	12	5.5	0.6	15.5	
PPL05251□A2D0		250	65	32	400	0.3	7.0	5.0	0.6	10.5	
PPL05381□A2D0		380	56	30	400	0.3	7.0	5.0	0.6	10.5	
PPL05561□A2D0		560	44	22	400	0.3	7.0	5.0	0.6	10.5	
PPL05601□A2D0		600	39	21	380	0.2	7.0	5.0	0.6	10.5	
PPL05122□AEE0		1200	30	15	500	0.1	7.0	5.0	0.6	10.5	
PPL05152□AEE0	1500	24	12	500	0.1	7.0	5.0	0.6	10.5		
PPL05801□P9F0	90±10	800	36	18	600	0.3	7.0	5.0	0.6	10.5	
PPL05102□P9F0		1000	30	15	600	0.3	7.0	5.0	0.6	10.5	
PPL05132□P9F0		1300	26	13	600	0.3	7.0	5.0	0.6	10.5	
PPL08700□A2C8	120±10	70	127	64	380	1.4	8.5	7.0	0.6	13.5	
PPL08121□A2C8		120	100	49	380	1.4	8.5	7.0	0.6	13.5	
PPL08151□A2C8		150	86	43	380	1.4	8.5	7.0	0.6	13.5	
PPL11250□A2C8		25	245	123	380	2.0	12.5	7.0	0.6	16.5	
PPL11500□A2C8		50	173	87	380	2.0	12.5	7.0	0.6	16.5	
PPL11800□A2C8		80	137	69	380	2.0	12.5	7.0	0.6	16.5	
PPL11121□A2C8		120	112	56	380	2.0	12.5	7.0	0.6	16.5	
PPL11151□A2C8		150	100	50	380	2.0	12.5	7.0	0.6	16.5	
PPL08501□A2E0		500	48	24	500	1.0	8.5	7.0	0.6	13.5	
PPL08112□AEE0		1100	32	16	500	1.0	8.5	7.0	0.6	13.5	
PPL11501□AEE0	500	55	28	500	1.4	12.5	7.0	0.6	16.5		
PPL11752□A1J0	110±10	7500	17	8	1000	0.5	12.5	7.0	0.6	16.5	

Note: □=Tolerance of R<sub>25</sub>



● Reliability Test

Item	Test Condition / Methods	Standard
Resistance to Soldering Heat *	Temperature: 350 ± °C Duration: 3~4 s	IEC60068-2-20 Test T <sub>b</sub>
Robustness of Termination *	Tensile, bending and torsion tests as appropriate to type termination	IEC60068-2-21
Rapid Change of Temperature	T <sub>A</sub> =LCT T <sub>B</sub> =UCT Number of cycles:5 Duration: 30 min	IEC60068-2-14 Test N <sub>a</sub>
Vibration *	Frequency :10-55 Hz h= 0.75 min Duration: 6 h	IEC 60068-2-6 Test F <sub>c</sub>
Shock *	Pulse shape: half-sine Acceleration: 50m/s <sup>2</sup> Pulse duration: 30 ms	IEC 60068-2-27 Test E <sub>a</sub>
Climatic Sequence *	Dry heat :T= 40°C, 24hrs , 20%Rh Damp heat first cycle: T=40°C 95% R h Cold: T=0°C, 2hrs Damp heat 5 cycles	IEC 60068-2-2 Test Ba IEC 60068-2-30 Test D <sub>b</sub> IEC 60068-2-1 Test A <sub>a</sub>
Thermal Time Constant by Cooling	63.2% of temperature excess	IEC 60738-1
Temperature Coefficient of Resistance	$\alpha_T = \ln(R_{T_C+25}/R_{T_C+10}) / 15$ R <sub>T<sub>C</sub></sub> =2R <sub>min</sub>	IEC 60738-1
Dissipation Factor at V <sub>max</sub>	Voltage: V <sub>max</sub> Current: <I <sub>max</sub>	IEC 60738-1
Endurance at Upper Category Temperature	Temperature: UCT Duration: 1000 hrs	IEC 60738-1
Endurance at Maximum Operating Temperature and Maximum Voltage	Voltage: V <sub>max</sub> Temperature: UCT Current: <I <sub>max</sub> Duration: 1000 hrs	IEC 60738-1
Endurance at Room Temperature (Cycling)	Voltage: V <sub>max</sub> Temperature: 25 ±5°C Current: ≤I <sub>max</sub> Number of cycle 1,000、10,000 or 100,000	IEC 60738-1
Damp Heat Steady State	Temperature: 40 ±5°C Relative humidity of air: 95~98%Rh Duration: 1000 hrs	IEC 60068-2-3 Test C <sub>a</sub>

\* : Only application for PPL series