



NTC Thermistor

PRODUCT DATA

■ Temperature Compensation/Sensing TCF Series (Lead Frame Type)

● Features

1. Body size $\phi 3\text{mm}$
2. Radial lead resin coated
3. $-40 \sim +100^\circ\text{C}$ operating temperature range
4. Wide resistance range
5. Cost effective

● Recommended applications

1. Home appliances (air conditioner, refrigerator, electric fan, electric cooker, washing machine, microwave oven, drinking machine, CTV, radio.)
2. Automotive electronics
3. Computers
4. Digital meter



● Approvals



* UL 1434 Recognized (File#E138827)

● Dimensions

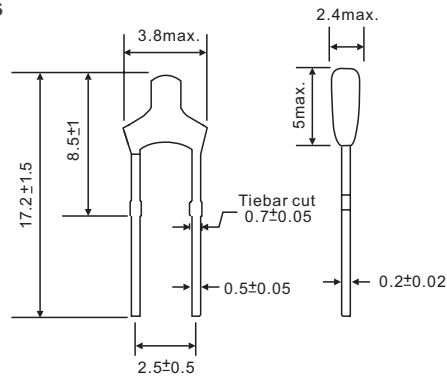

(Unit:mm)

● Characteristics

| Part no. | Zero power resistance at 25°C (K Ω) | Tolerance of resistance ($\pm\%$) | B value (K) | Tolerance of B value (%) | Max. power rating at 25°C (mW) | Thermal dissipation constant (mW/°C) | Thermal time constant (Sec.) | Operating temperature range (°C) |
|---------------|---|-------------------------------------|-------------|--------------------------|--------------------------------|--------------------------------------|------------------------------|----------------------------------|
| TCF3A202□318* | 2 | 1、2、3、5、10 | 25/85 | 1、2、3 | 150 | ≥ 2 | ≤ 12 | -40 ~ +100 |
| TCF3A502□33C* | 5 | | | | | | | |
| TCF3A103□34D* | 10 | | | | | | | |
| TCF3A123□347* | 12 | | | | | | | |
| TCF3A203□40B* | 20 | | | | | | | |
| TCF3A303□409* | 30 | | | | | | | |
| TCF3A333□409* | 33 | | | | | | | |
| TCF3A473□409* | 47 | | | | | | | |
| TCF3A503□406* | 50 | | | | | | | |
| TCF3A104□419* | 100 | | | | | | | |
| TCF3A104□419* | 100 | | | | | | | |

Note 1: □ = Tolerance of resistance

Note 2: * = Tolerance of B value

● **Reliability test**

| Item | Standard | Test conditions / Methods | Specifications | | | | | | | | | | | | | | | |
|---|-----------------------------|--|---|------------------|------------------|------|-------------------|--------|---|------------------|-------|---|---------|--------|---|------------------|-------|-------------------------------------|
| Tensile Strength of Terminals | IEC68-2-21 | <p>Gradually applying the force specified below to each terminal and keeping the unit fixed for 10±1 sec.</p> <table style="width: 100%; border: none;"> <tr> <td style="text-align: center; border-bottom: 1px solid black;">Terminal cross-sectional area (mm²)</td> <td style="text-align: center; border-bottom: 1px solid black;">Force (kg)</td> </tr> <tr> <td style="text-align: center;">0.07<S≤0.2</td> <td style="text-align: center;">0.5</td> </tr> </table> | Terminal cross-sectional area (mm ²) | Force (kg) | 0.07<S≤0.2 | 0.5 | No visible damage | | | | | | | | | | | |
| Terminal cross-sectional area (mm ²) | Force (kg) | | | | | | | | | | | | | | | | | |
| 0.07<S≤0.2 | 0.5 | | | | | | | | | | | | | | | | | |
| Bending Strength of Terminals | IEC68-2-21 | <p>Hanging the force specified below to each terminal and gradually bending each terminal by 90° in one direction, then 90° in the opposite direction, and again back to the origin.</p> <table style="width: 100%; border: none;"> <tr> <td style="text-align: center; border-bottom: 1px solid black;">Terminal cross-sectional area (mm²)</td> <td style="text-align: center; border-bottom: 1px solid black;">Force (kg)</td> </tr> <tr> <td style="text-align: center;">0.07<S≤0.2</td> <td style="text-align: center;">0.25</td> </tr> </table> | Terminal cross-sectional area (mm ²) | Force (kg) | 0.07<S≤0.2 | 0.25 | No visible damage | | | | | | | | | | | |
| Terminal cross-sectional area (mm ²) | Force (kg) | | | | | | | | | | | | | | | | | |
| 0.07<S≤0.2 | 0.25 | | | | | | | | | | | | | | | | | |
| Solderability | IEC68-2-20 | 235 ± 5 °C , 2 ± 0.5 sec | At least 95% of terminal electrode is covered by new solder | | | | | | | | | | | | | | | |
| Resistance to Soldering Heat | IEC68-2-20 | 260 ± 5 °C , 10 ± 1 sec | No visible damage ΔR/R ≤ 3 % | | | | | | | | | | | | | | | |
| High Temperature Storage | IEC68-2-2 UL1434 | 100 ± 5 °C , 1000 ± 24 HRS | No visible damage ΔR/R ≤ 5% | | | | | | | | | | | | | | | |
| Damp Heat | IEC68-2-3 UL1434 | 40 ± 2 °C , 90 ~ 95 % RH , 1000 ± 24 HRS | No visible damage ΔR/R ≤ 3 % | | | | | | | | | | | | | | | |
| Thermal Shock | IEC68-2-14 UL1434 | <p>The thermal shock conditions shown below shall be repeated 5 cycles</p> <table border="1" style="margin-left: auto; margin-right: auto;"> <thead> <tr> <th>Step</th> <th>Temperature (°C)</th> <th>Period (minutes)</th> </tr> </thead> <tbody> <tr> <td style="text-align: center;">1</td> <td style="text-align: center;">-40 ± 5</td> <td style="text-align: center;">30 ± 3</td> </tr> <tr> <td style="text-align: center;">2</td> <td style="text-align: center;">Room temperature</td> <td style="text-align: center;">5 ± 3</td> </tr> <tr> <td style="text-align: center;">3</td> <td style="text-align: center;">100 ± 5</td> <td style="text-align: center;">30 ± 3</td> </tr> <tr> <td style="text-align: center;">4</td> <td style="text-align: center;">Room temperature</td> <td style="text-align: center;">5 ± 3</td> </tr> </tbody> </table> | Step | Temperature (°C) | Period (minutes) | 1 | -40 ± 5 | 30 ± 3 | 2 | Room temperature | 5 ± 3 | 3 | 100 ± 5 | 30 ± 3 | 4 | Room temperature | 5 ± 3 | No visible damage ΔR/R ≤ 3 % |
| Step | Temperature (°C) | Period (minutes) | | | | | | | | | | | | | | | | |
| 1 | -40 ± 5 | 30 ± 3 | | | | | | | | | | | | | | | | |
| 2 | Room temperature | 5 ± 3 | | | | | | | | | | | | | | | | |
| 3 | 100 ± 5 | 30 ± 3 | | | | | | | | | | | | | | | | |
| 4 | Room temperature | 5 ± 3 | | | | | | | | | | | | | | | | |
| Life Test | CNS5550 | 25 ± 5 °C , Pmax. , 1000 ± 24 HRS | No visible damage ΔR/R ≤ 5 % | | | | | | | | | | | | | | | |
| Insulation test | MIL-STD-202F- Method 302 | 500 V _{DC} 1 min | No visible damage ≥ 100 MΩ | | | | | | | | | | | | | | | |
| Insulation test | MIL-STD-202F- Method 301 | 1000 V _{AC} 10 mA 1 min | No visible damage | | | | | | | | | | | | | | | |

Products have been tested at Thinking Electronic Industrial Co., Ltd. Laboratory recognized by UL (Underwriters Laboratories Inc.) under CTDTP (Client Test Data Program).